



H&R Spezialfedern GmbH & Co. KG, Elspers Straße 36, 57368 Lennestadt
Telefon (02721) 92600 • Telefax (02721) 10708

www.h-r.com

Instruction for Body Lowering Kit Audi A8/ 29244-2

Indication

The colours e.g. red/blue, mean thick red with small blue. All not mentioned cable-sections are 0,5mm². All mentioned sides are in driving direction.

Mounting

The modul is mounted to the ECU which is behind the glove-box/CD player in the passenger compartment. It is fitted with Velcro strip on the ECU.

The CD-player has to be pulled out with the original Audi – tool no. 4D0 051 530. There are 8 torx-screws to be loosen. The ECU in an aluminium-box with two big plugs is on the left. Fit the ETS modul with Velco strip under the glove-box.

The butt connectors are connected to the plugs of the ECU. Connect the leads as described in the figure and fit the butt connectors.

The PIN-numbers are obligatory, the cable colours can differ.

Do not loosen the plugs from the ECU as an error could appear then. This error blocks the height adjustment and deletes itself after a few kilometres driving. There are two cables bl/li – please note the PIN-numbers.

Test

- replace tape + cable combinder
- shrink the watertight butt connectors
- lift and lower the car with the switch inside the car
- check the connections

An axle alignment must not be done as the ride height is less even at low speed to have enough comfort. If an axle alignment has to be done due to other reasons it has to be done when the car is in original height. In this case the diagnostic plug has to be used.

Adjusting

The lowering can be adjusted for about. ± 15 mm. The hole with 2 points is for adjusting both axles (first step), the hole with 1 point is for adjusting the rear axle only (second step).

Carefully turn with a small screw driver. One turn clockwise means 2mm lower. After adjusting lift and lower the car with the switch inside the car to realize the adjustment.

Handling problems

To solve any problems you can use the adapter plug to replace the lowering modul and to bring back the car into the original condition without changing the cables. The adaptor plug has to be carried in the car always.

If there are any doubts about the speed control lifting, maybe because the suspension is too hard at high speed, this can be tested as follows: behind the adjustment-hole for the rear axle there is a little lamp. The speed control works when this lamp flickers when ignition is on.

Audi A8

Original ECU

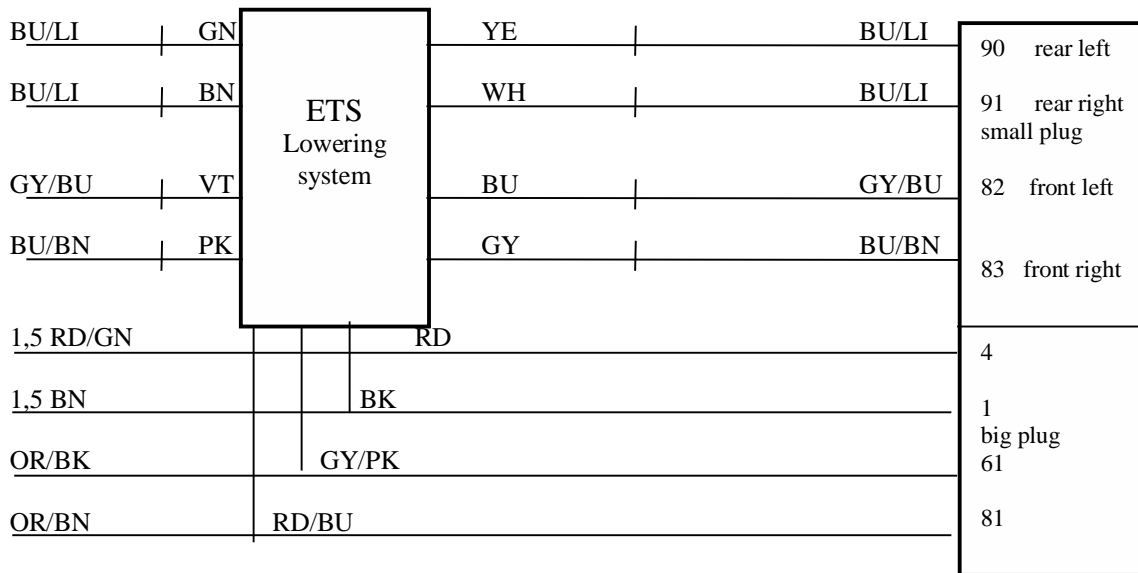

The cable colours

GN/green
BN/brown
VT/violet
WH/white
RD/red
OR/orange

GY/grey
PK/pink
YE/yellow
BU/blue
BK/black
LI/ lilac

