



H&R Spezialfedern GmbH & Co. KG, Elspey Straße 36, 57368 Lennestadt  
Telefon (02721) 92600 • Telefax (02721) 10708

[www.h-r.com](http://www.h-r.com)

## **Instruction for Body Lowering ETS Cayenne / Touareg/ 29244**

### **Indication**

The colours e.g. red/blue, mean thick red with small blue. All not mentioned cable-sections are 0,5 mm<sup>2</sup>. All mentioned sides are in driving direction.

### **Mounting**

The module is mounted inside the car, under the cover of the first aid kit.. It is fitted with Velcro strip on the Porsche/VW-ECU. Install the cables and attach crimp connections like shown in the drawing below. Do not disconnect the two plugs of the Porsche/VW-ECU, this will cause an error which makes the level-adjusting impossible. The error will disappear only after some miles driving. The butt connectors are connected to the two plugs of the Porsche/VW-ECU. The module leads red (12V) and black (GND) are soldered. Connect the leads as described in the figure and fit the butt connectors.

The doors of the car have to be closed when the ride-height control switch in the centre console is used.

### **Test**

- replace tape + cable combinder
- shrink the watertight butt connectors
- lift and lower the car with the switch inside the car
- check the connections

An axle alignment must not be done as the ride height is less even at low speed to have enough comfort. If an axle alignment has to be done due to other reasons it has to be done when the car is in original height. In this case the diagnostic plug has to be used.

### **Fine adjusting**

The lowering can be adjusted for about.  $\pm 20$ mm. The hole with 2 points is for adjusting both axles (step 1), the hole with 1 point is for adjusting the rear axle (step 2).

Carefully turn with a small screw driver. One turn clockwise means 2mm lower. After adjusting lift and lower the car with the switch inside the car to realize the adjustment.

### **Handling problems & Reset system**

To solve your problems and to bring back the car into the original condition you have to use the adapter plug which has to be carried in the car.

The lowering modul is replaced by the plug without changing the cables. For analysing the problem a plot with the diagnostic-system is useful.

If the lowering works but the lowest level can not be reached after testing (leads to an error-warning) this is a sign for a too extensive lowering. By turning the the points clockwise this can be solved.

If there are doubts about the speed-sensitive lowering , maybe because the springs are too hard at high speed driving, this can be checked as following: Behind the adjusting point for the rear axle there is a little light. When this is flickering when ignition is on, the speed-sensitive lowering works correctly.

## Cayenne / Touareg

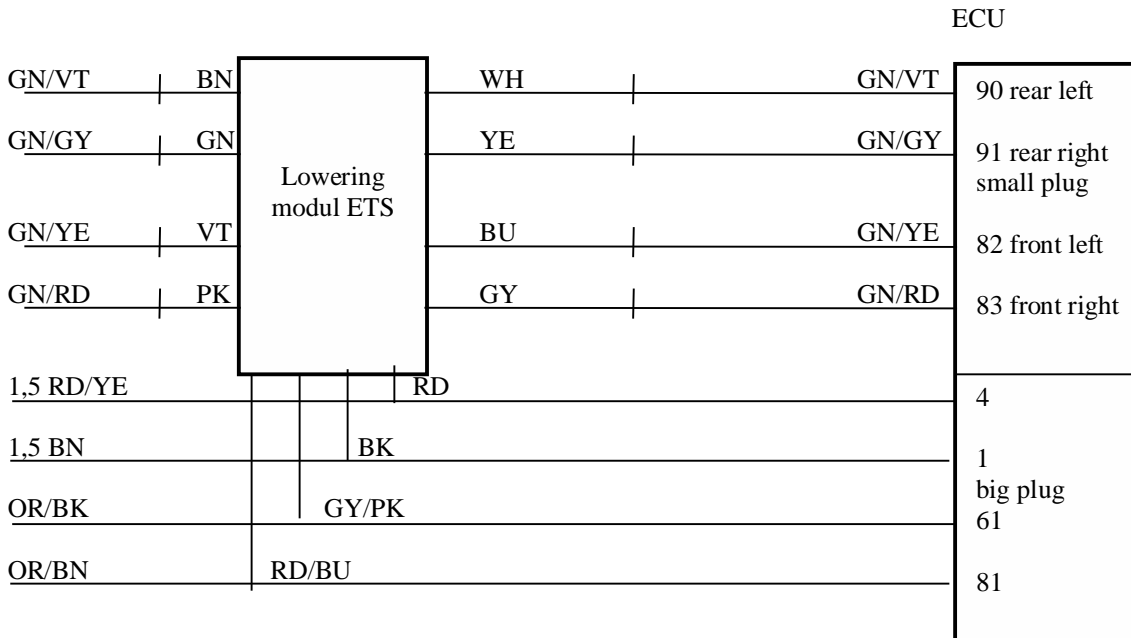

### The cable colours

gn/grün	GN/green
br/braun	BN/brown
vi/violett	VT/violet
ws/weiß	WH/white
ro/rot	RD/red
or/orange	OR/orange

gr/grau	GY/grey
rs/rosa	PK/pink
ge/gelb	YE/yellow
bl/blau	BU/blue
sw/schwarz	BK/black

